

General Description

The GP-3030-MTGN is a complete GPS&GLONASS engine module that features super sensitivity, ultra low power and small form factor. The GPS&GLONASS signal is applied to the antenna input of module, and a complete serial data message with position, velocity and time information is presented at the serial interface with NMEA protocol or custom protocol.

Its -165dBm tracking sensitivity extends positioning coverage into place like urban canyons and dense foliage environment where the GPS&GLONASS was not possible before. The small form factor and low power consumption make the module easy to integrate into portable device like PNDs, mobile phones, cameras and vehicle navigation systems.

Applications

- LBS (Location Based Service)
- PND (Portable Navigation Device)
- Vehicle navigation system
- Mobile phone

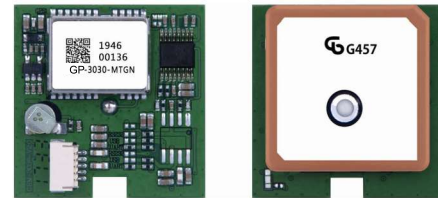

**Figure : GP -3030- MTGN
Top View**

Features

- Build on high performance, low-power MediaTek MT3333 chipset
- Ultra high Track sensitivity: -165dBm
- Extremely fast TTFF at low signal level
- Built-in high gain LNA
- Built-in super capacitor for backup ephemeris
- Low power consumption: Max $45\text{mA}@3.3\text{V}$
- NMEA-0183 compliant protocol
- Operating voltage: 3.0V to 5.0V
- Operating temperature range: $-40\text{to}85^\circ\text{C}$
- Patch Antenna Size: $25\times 25\times 4\text{mm}$
- Small form factor: $30\times 30\times 6.4\text{mm}$
- Communication type: RS232
- RoHS compliant (Lead-free)

1 Description

1.1. Key Features

Parameter	Specification
Power Supply	<ul style="list-style-type: none"> Supply voltage: 3.0V~5.0V Typical: 3.3V
Power Consumption	<ul style="list-style-type: none"> Acquisition: 45mA @VCC=VBAT=3.3V Tracking: 40mA @VCC=VBAT=3.3V Backup: 15uA @VBAT=3.3V
Receiver Type	<ul style="list-style-type: none"> Code 66 search channels, 22 synchronous tracking channels GPS&QZSS L1 1575.42MHz C/A , GLONASS L1OF 1602MHz, SBAS: WAAS, EGNOS, MSAS, GAGAN
Sensitivity	<ul style="list-style-type: none"> Tracking: -165dBm Re-acquisition: -156dBm Acquisition: -146dBm
TTF (Autonomous)	<ul style="list-style-type: none"> Cold start: 35s typ @-130dBm Warm start: 30s typ @-130dBm Hot start: 1s typ @-130dBm
Horizontal Position Accuracy (Autonomous)	<ul style="list-style-type: none"> <2.5m CEP @-130 dBm
Max Update Rate	<ul style="list-style-type: none"> Up to 10Hz,1Hz by fault
Accuracy of 1PPS Signal	<ul style="list-style-type: none"> not enabled
Acceleration Accuracy	<ul style="list-style-type: none"> Without aid: 0.1m/s²
Dynamic Performance	<ul style="list-style-type: none"> Maximum altitude: 18,000m Maximum velocity: 515m/s Acceleration: 4G
RS232 Port	<ul style="list-style-type: none"> RS232 Port: RS232_ TXD and RS232_ RXD Supports baud rate from 4800bps to 115200bps, 9600bps by default RS232 port is used for NMEA output, MTK proprietary commands input and firmware upgrade
Temperature Range	<ul style="list-style-type: none"> Normal operation: -40°C ~ +85°C Storage temperature: -45°C ~ +125°C
Physical Characteristics	<ul style="list-style-type: none"> Size: 30±0.20 ×30±0.20 ×6.4±0.20mm Communication type: RS232 Weight: Approx.12.6g

1.2 Power Supply

Regulated power for the GP -3030- MTGN is required. The VCC Pin Need a stable DC voltage supply. Power supply ripple must be less than 30mV. The input voltage Vcc should be 3.0V~5.0V, Recommended power supply voltage is 3.3V . maximum current is 45mA. Suitable decoupling must be provided by external decoupling circuitry.

1.3 RS232 Ports

The module supports two full duplex serial channels RS232. All serial connections are at 5.0V RS232 logic levels, if need different voltage levels, use appropriate level shifters. The baud rate of both serial ports are fully programmable, the data format is however fixed: X, N, 8, 1, i.e. X baud rate, no parity, eight data bits and one stop bit, no other data formats are supported, LSB is sent first. The modules default baud rate is set up 9600bps, however, the user can change the default baud rate to any value from 4800 bps to 38400kbps. RS232 is used e.g. for booting and NMEA interface.

2 Application

The GP -3030- MTGN module is equipped with a 5-pin connector that connects to your application platform.

It consists of a MediaTek MT3333 single chip GNSS IC which includes the RF part and Baseband part, a patch antenna, a RS232 level conversion chip,a LNA, a SAW filter, a TCXO, a crystal oscillator, Also comes with a 0.22F crystal capacitor ,can backup satellite ephemeris about 2 hour.

2.1. Pin Assignment

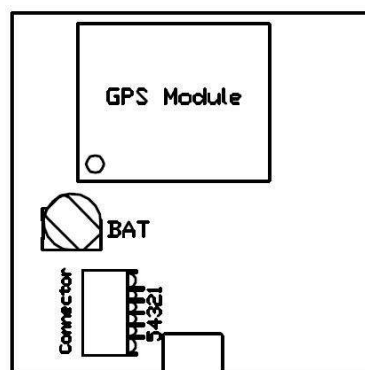

Figure 2: Pin Assignment

GP-3030-MTGN GNSS Receivers Module

Pin No.	Pin name	I/O	Description	Remark
1	VCC	I	Module Power Supply	
2	GND	G	Ground	
3	GND	G	Ground	
4	RS232-TXD	O	RS232 Serial Data output	
5	RS232-RXD	I	RS232 Serial Data Input	

2.2 Mechanical Dimensions

This chapter describes the mechanical dimensions of the GP -3030- MTGN module. Size unit (mm) .

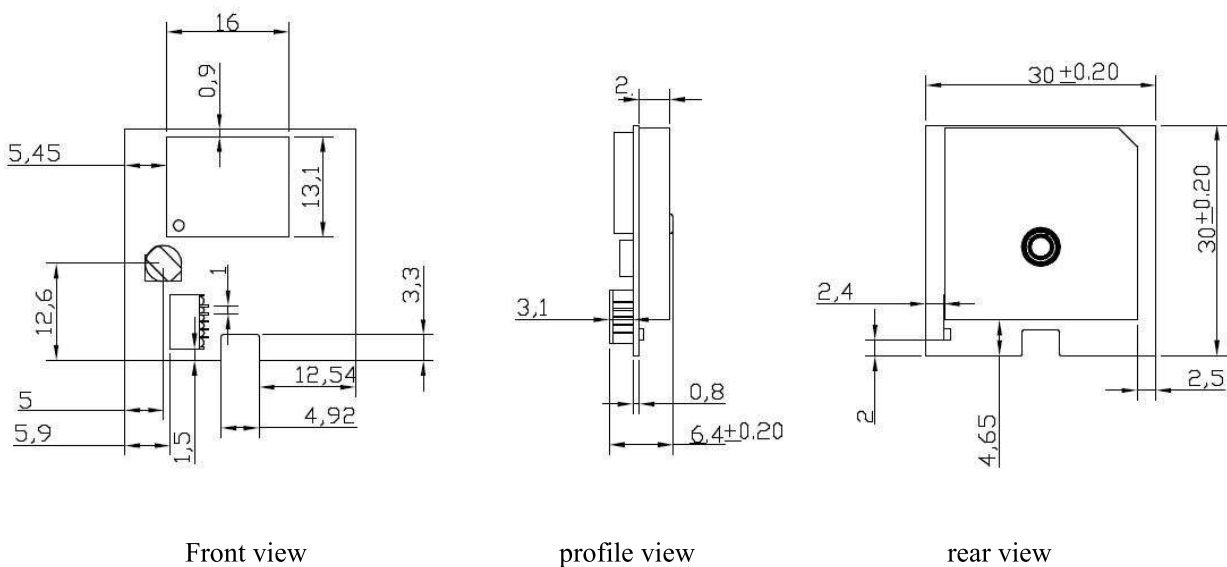

Figure 3: Specification size chart

3 NMEA 0183 Protocol

The NMEA protocol is an ASCII-based protocol, Records start with a \$ and with carriage return/line feed. GPS&GLONASS specific messages all start with \$GPxxx/\$GLxxx where \$GNxxx is a three-letter identifier of the message data that follows. NMEA messages have a check sum, which allows detection of corrupted data transfers.

The GP -3030- MTGN Initialization location mode for GPS&GLONASS two system mode: GPS&GLONASS, Output data: \$GNRMC. \$GNGGA. \$GPGSV. \$GLGSV. \$GPGSA. \$GLGSA. \$GNGLL. \$GNVTG.

3.1 Location mode configuration instructions

Single system or dual system positioning mode can be selected through the configuration instructions, configuration instructions such as following table:

Instruction configuration instructions:

Pattern	Instructions	NMEA Out Put
GPS	\$PMTK353,1,0*36	GPRMC.GPGGA.GPGSV.GPGSA.GPGLL.GPVTG
GLONASS	\$PMTK353,0,1*36	GLRMC.GLGGA.GLGSV.GLGSA.GLGLL.GLVTG
GPS&GLONASS	\$PMTK353,1,1*37	GNRMC.GNGGA.GPGSV. GLGSV.GPGSA.GLGSA. GNGLL.GNVTG

✧ The GP -3030- MTGN initialization location mode for GPS&GLONASS dual mode.

3.2 NMEA-0183 data Detailed field

3.2.1 GGA-Global Positioning System Fixed Data

\$xxGGA, 161229.487,3723.2475,N, 12158.3416,W, 1,07,1,0,9,0,M,0000*18

Table 1: GGA Data Format

Name	Example	Units	Description
Message ID	\$xxGGA		GGA protocol header
UTC Position	161229.487		hhmmss.sss
Latitude	3723.2457		ddmm.mmmm
N/S indicator	N		N=north or S=south
Longitude	12158.3416		dddmm.mmmm
E/W Indicator	W		E=east or W=west
Position Fix Indicator	1		See Table 1-1
Satellites Used	07		Range 0 to 12
HDOP	1.0		Horizontal Dilution of Precision

MSL Altitude	9.0	meters	
Units	M	meters	
Geoids Separation		meters	
Units	M	meters	
Age of Diff.Corr.		second	Null fields when DGPS is not Used
Diff.Ref.Station ID	0000		
Check sum	*18		
<CR> <LF>			End of message termination

Table 1-1: Position Fix Indicators

Value	Description
0	Fix not available or invalid
1	GPS&GLONASS SPS Mode, fix valid
2	Differential GPS&GLONASS, SPS Mode, fix valid
3	GPS&GLONASS PPS Mode, fix valid

3.2.2 GLL-Geographic Position - Latitude/Longitude

\$xxGLL , 3723.2475, N,12158.3416, W,161229.487, A*2C.

Table 2: GLL Data Format

Name	Example	Units	Description
Message ID	\$xxGLL		GLL protocol header
Latitude	3723.2475		ddmm.mmmmm
N/S Indicator	N		N=north or S=south
Longitude	12158.3416		dddmm.mmmmm
E/W Indicator	W		E=east or W=west
UTC Position	161229.487		hhmmss.sss
Status	A		A=data valid or V=data not valid
Check sum	*2C		
<CR> <LF>			End of message termination

3.2.3 GSA-GPS&GLONASS DOP and Active Satellites

\$xxGSA , A, 3, 07, 02, 26,27, 09, 04,15, , , , , 1.8,1.0,1.5*33.

Table 3: GSA Data Format

Name	Example	Units	Description
Message	\$xxGSA		GSA protocol header
Mode 1	A		See Table 3-2
Mode 2	3		See Table 3-1
Satellite Used	07		Sv on Channel 1
Satellite Used	02		Sv on Channel 2
...
Satellite Used			Sv on Channel 66
PDOP	1.8		Position Dilution of Precision
HDOP	1.0		Horizontal Dilution of Precision
VDOP	1.5		Vertical Dilution of Precision
Check sum	*33		
<CR> <LF>			End of message termination

Table 3-1: Mode 1

Value	Description
1	Fix not available
2	2D
3	3D

Table 3-2: Mode 2

Value	Description
M	Manual-forced to operate in 2D or 3D mode
A	Automatic-allowed to automatically switch 2D/3D

3.2.4 GSV-GPS&GLONASS Satellites in View

\$xxGSV , 2, 1, 07, 07, 79,048, 42, 02, 51,062, 43, 26, 36,256, 42, 27, 27, 138,42*71

\$xxGSV, 2, 2, 07, 09, 23,313, 42, 04, 19, 159, 41, 15,12,041, 42*41.

Table 4: GSV Data Format

Name	Example	Units	Description
Message ID	\$xxGSV		GSV protocol header
Number of Message	2		Range 1 to 3
Message Number	1		Range 1 to 3
Satellites in View	07		
Satellite ID	07		Channel 1(Range 1 to 66)

Elevation	79	degrees	Channel 1(Maximum 90)
Azinmuth	048	degrees	Channel 1(True, Range 0 to 359)
SNR(C/NO)	42	dBHz	Range 0 to 99,null when not tracking
...			...
Satellite ID	27		Channel 4(Range 1 to 66)
Elevation	27	degrees	Channel 4(Maximum 90)
Azimuth	138	degrees	Channel 4(True, Range 0 to 359)
SNR(C/NO)	42	dBHz	Range 0 to 99, null when not tracking
Check sum	*71		
<CR> <LF>			End of message termination

✧ Depending on the number of satellites tracked multiple messages of GSV data may be required.

3.2.5 RMC-Recommended Minimum Specific GPS&GLONASS Data

\$xxRMC, 161229.487, A, 3723.2475, N, 12158.3416, W, 0.13,309.62, 120598,, *10

Table 5: RMC Data Format

Name	Example	Units	Description
Message ID	\$xxRMC		RMC protocol header
UTS Position	161229.487		hhmmss.sss
Status	A		A=data valid or V=data not valid
Latitude	3723.2475		ddmm.mmmm
N/S Indicator	N		N=north or S=south
Longitude	12158.3416		dddmm.mmmm
E/W Indicator	W		E=east or W=west
Speed Over Ground	0.13	Knots	
Course Over	309.62	Degrees	True
Ground			
Date	120598		Dummy
Magnetic variation		Degrees	E=east or W=west
Check sum	*10		
<CR> <LF>			End of message termination

3.2.6 VTG-Course Over Ground and Ground Speed

\$xxVTG, 309.62, T, M, 0.13, N, 0.2, K*6E

Table 6: VTG Data Format

Name	Example	Units	Description
Message ID	\$xxVTG		VTG protocol header
Course	309.62	Degrees	Measured heading
Reference	T		True
Course		Degrees	Measured heading
Reference	M		Magnetic
Speed	0.13	Knots	Measured horizontal speed
Units	N		Knots
Speed	0.2	Km/hr	Measured horizontal speed
Units	K		Kilometer per hour
Check sum	*6E		
<CR> <LF>			End of message termination