

# GPS Active Antenna

**Model: GEA001**



1 Part Number

**GE A 001**

Serial Number

A: Active Antenna

GE: GPS External Antenna

2 Dimension (Unit: mm)

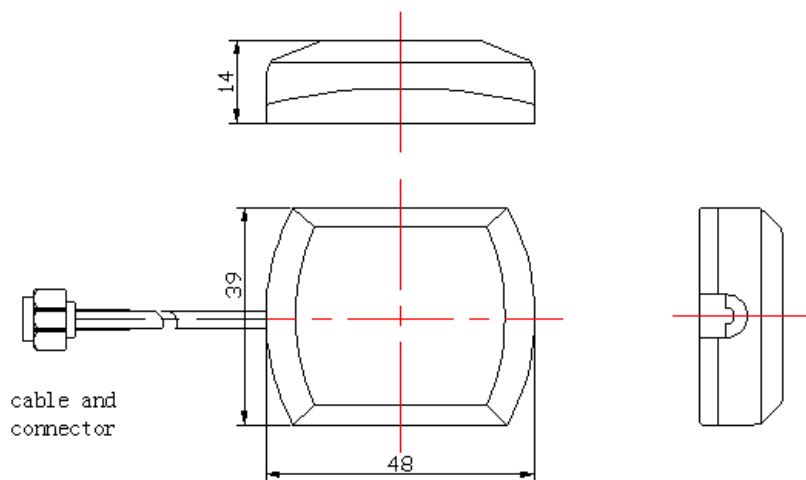

### 3 Electrical Characteristics

#### 3.1 Dielectric Antenna

Form 1

No.	Item	Specifications	Post Environmental Tolerance
1	Center Frequency (MHz)	1575.42 MHz	±3 MHz
2	Band Width (MHz)	±5 MHz	±1 MHz
3	V.S.W.R (in BW)	1.5 : 1	—
4	Gain (Zenith)	3 dB	±0.5 dB
5	Polarization	RHCP	—
6	Impedance	50	—

#### 3.2 LNA/Filter

Form 2

No.	Item	Specifications	Post Environmental Tolerance
1	LNA Gain	28±2 dB	±2.5 dB
2	Noise Figure	1.5 dB	—
3	Filter Out Band Attenuation	12dB Min f0+50MHz 16dB Min f0-50MHz	±1.0 dB
4	DC Voltage	2.2~5 V	
5	DC Current	5~15 mA	

#### 3.3 Mechanical

Form 3

No.	Item	Specification
1	Cable	RG174 3m/5m or others
2	Connector	SMA/SMB/MCX or others
3	Plastic Housing	Black
4	Mounting	Magnet/Adhesive

#### 4 Reliability

Condition: Temperature:  $40 \pm 5^{\circ}\text{C}$

Load: DC=5V  $\pm 0.5\text{ V}$

Quantity: 2000pcs

Sustained Time: 480h

#### 5 Environmental Specifications

Post Environmental Tolerance (Refer to the form 1~2 )

Condition: Temperature range  $25 \pm 3^{\circ}\text{C}$

Relative Humidity range 55~75%RH

Operating Temperature range  $-40^{\circ}\text{C} \sim +85^{\circ}\text{C}$

Storage Temperature range  $-40^{\circ}\text{C} \sim +100^{\circ}\text{C}$

##### 5.1 Moisture Proof

The device should satisfy the electrical characteristics specified in form 1~2 after exposed to the temperature  $40 \pm 2^{\circ}\text{C}$  and the relative humidity 90~95% RH for 96 hours and 1~2 hours recovery time under normal condition.

##### 5.2 Vibration Resist

The device should satisfy the electrical characteristics specified in form 1~2 after applied to the vibration of 10 to 55Hz with amplitude of 1.5mm for 2 hours each in X , Y and Z directions.

##### 5.3 Drop Shock

The device should satisfy the electrical characteristics specified in form 1~2 after dropping onto the hard wooden board from the height of 30cm for 3 times each facet of the 3 dimensions of the device.

##### 5.4 High Temperature Endurance

The device should satisfy the electrical characteristics specified in form 1~2 after exposed to temperature  $80 \pm 5^{\circ}\text{C}$  for  $24 \pm 2$  hours and 1~2 hours recovery time under normal temperature.

##### 5.5 Low Temperature Endurance

The device should also satisfy the electrical characteristics specified in form 1~2 after exposed to the temperature  $-40^{\circ}\text{C} \pm 5^{\circ}\text{C}$  for  $24 \pm 2$  hours and to 2 hours recovery time under normal temperature.

##### 5.6 Temperature Cycle Test

The device should also satisfy the electrical characteristics specified in form 1~2 after exposed to the low temperature  $-25^{\circ}\text{C}$  and high temperature  $+85^{\circ}\text{C}$  for  $30 \pm 2$  min each by 5 cycles and 1 to 2 hours recovery time under normal temperature.

#### 6 Weatherproof

Put the antennas in 1m deep water for 12h, and find 100% waterproof.